

NOTES: FOR MORE DETAILED DRAWING SEE V.P.TOOLING STANDARDS
 DIMENSIONS MARKED  ARE CONTROL DIMENSIONS

REVISIONS			
REV.	DESCRIPTION	DATE	APPROVED
A	INITIAL RELEASE	09-15-97	
B	CO 046 Drafting Update	09-27-07	Rick C.
C	Changed Post Specification	12-10-07	Rick C.
D	Changed Description to match Sales Part.	02-13-08	Rick C.

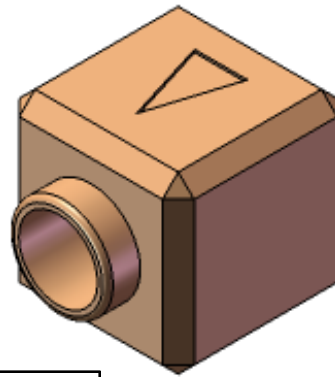
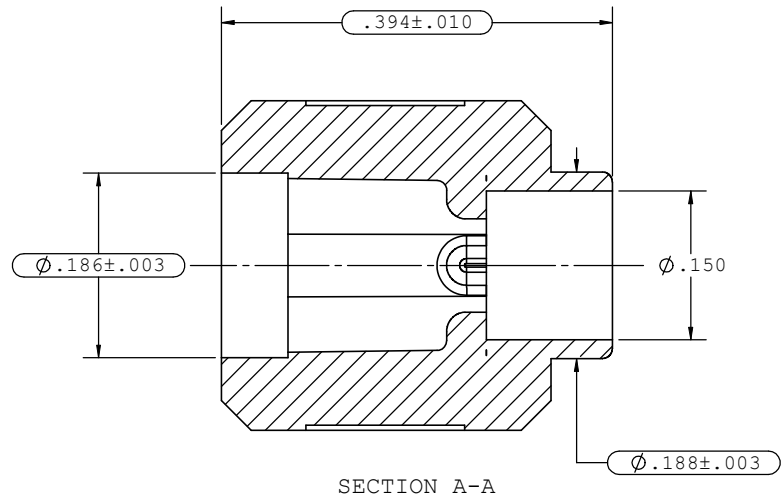
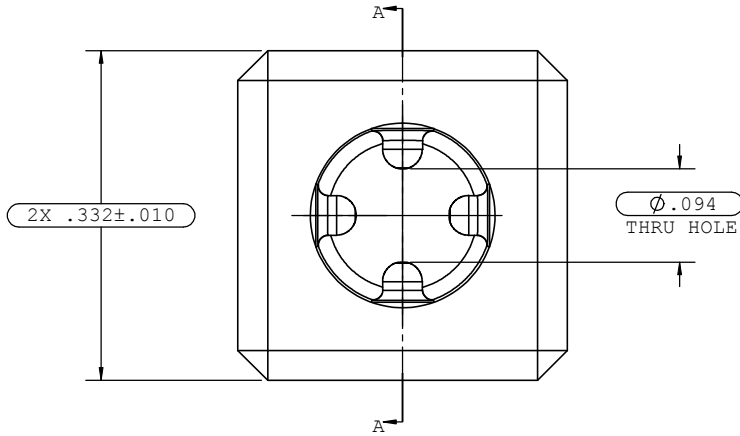

Dimension	Material Specific Tolerances							
	Acetal	Nylon	PP	ABS	PC	PVC	Polysulfone	PVDF
A								
B								
C								
D								
E								
F								

UNLESS OTHERWISE SPECIFIED DIMENSIONS ARE IN INCHES TOLERANCES ARE:		VALUE PLASTICS, INC			
FRACTIONS ±	DECIMAL .XX ±.01 .XXX ±.005 .XXXX ±.001	ANGULAR ± 1°	PART NUMBER: BDJ14		
DO NOT SCALE DRAWING			DESCRIPTION: Bondable Check Valve Junction Block (For use with RB01 or SB01)		
DRAWN BY: randy.sakurada	DATE: 3/26/2008	SIZE: B	SCALE: NTS	VER: 1008738	REV: D
ENGINEERING MGR: R. Cairns		© 2008 VALUE PLASTICS, INC			SHEET: 1 OF 1

NOTES: FOR MORE DETAILS SEE YOUR V.P. SERVICE REP.

REVISIONS			
REV.	DESCRIPTION	DATE	APPROVED
A	INITIAL RELEASE	09-15-97	
B	CO 046 Drafting Update	09-27-07	Rick C.
C	Changed Post Specification	12-10-07	Rick C.
D	Changed Description to match Sales Part.	02-13-08	Rick C.

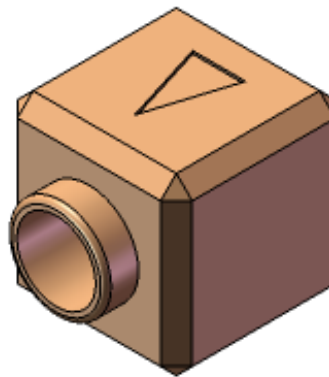
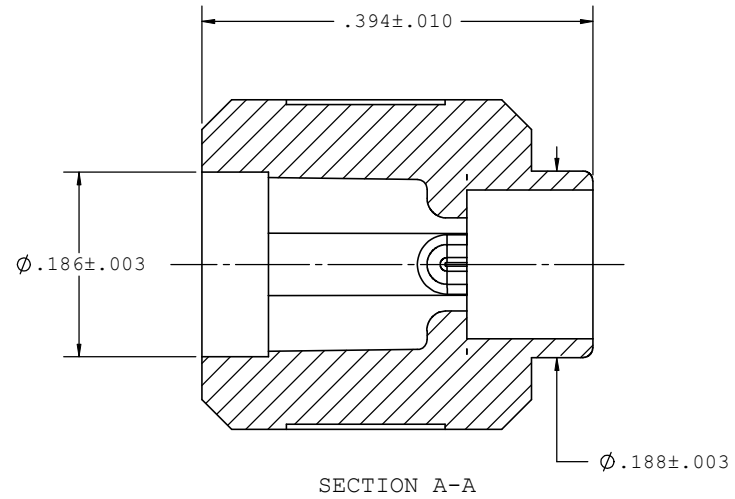
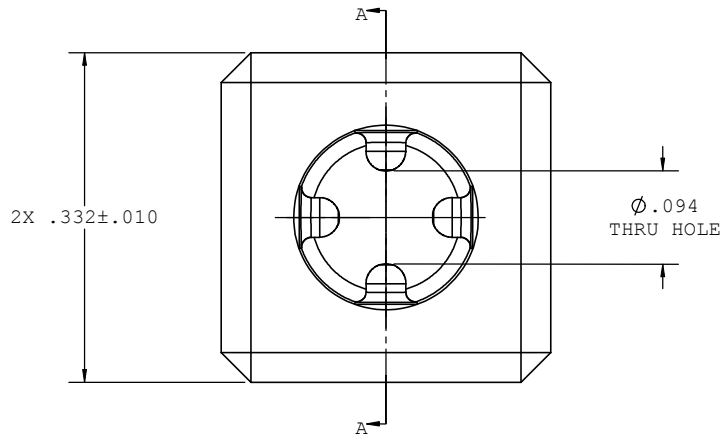

UNLESS OTHERWISE SPECIFIED
DIMENSIONS ARE IN INCHES
TOLERANCES ARE:
FRACTIONS DECIMAL ANGULAR
± .XXX ±.01 ± 1°
± .XXX ±.005
± .XXXX ±.001
DO NOT SCALE DRAWING

VALUE PLASTICS, INC

PART NUMBER: BDJ14

DESCRIPTION: Bondable Check Valve Junction Block
(For use with RB01 or SB01)

DRAWN BY: randy.sakurada DATE: 3/26/2008

SIZE: B SCALE: NTS VER: DWG. NO. 1008738 REV: D

ENGINEERING MGR: R. Cairns

© 2008 VALUE PLASTICS, INC SHEET: 1 OF 1

FOR REFERENCE ONLY